

# CL16.8VDC-5.0A



- automatic charger for 16.8 V lithium-ion battery packs

## CHARACTERISTIC:

- standard charging mode: first charging CC (constant current), then keeping CV ready (constant voltage)
- reliable and efficient
- compliance with standards
- safe power source
- high efficiency and low power consumption during buffer operation
- built-in power factor corrector

## APPLICATION:

- mobile and transport devices
- electric bikes
- buffered power supplies
- uninterruptable power supply systems
- industrial systems



The **CL16.8VDC-5.0A** is a high-performance and efficient 5 A charger for lithium-ion batteries in a small desktop enclosure. It supports 4S packets (four cells connected in series) and is designed to be charged at normal speed and to keep the batteries ready. Its design is based on high-quality electronic components that allow for continuous, long-term operation in all conditions.

The range of supported battery capacities for standard charging is 84 Wh (1C) – 168 Wh (0.5C).

## TECHNICAL CHARACTERISTICS

Group	Parameter	Value	Conditions
Input	Rated input voltage	230 VAC	
	Input voltage range	100-240 VAC	
	Mains frequency range	50-60 Hz	
	AC current (max.)	1.1 A	At 240 VAC and full load
	Inrush current (max.)	50 A	At 240 VAC and full load
	Input leakage current (max.)	Max. 0.25 mA	At 264 VAC
	No-load power consumption	Max. 0.15 W	
	Efficiency (typ.)	85%	
	Power factor	Min. 0.9	
Output	Charging method	CC/CV	
	Rated output voltage	16.8 V	With no load
	Minimum CV mode output voltage	16.4 V	With no load
	Maximum CV mode output voltage	17 V	With no load
	Rated output current	5 A	
	Lowest CC mode current	4.8 A	
	Highest CC mode current	5.2 A	
	Rated output power	85 W	
	DC voltage rise time (max.)	Up to 40 ms	At 100 VAC and full load
Hold up time (max.)	5 ms	At 100 VAC and full load	
Turn on delay time (max.)	Up to 3 s	At 100 VAC and full load	
Environmental	Working temperature	0°C to +40°C	
	Working humidity	5% to 90% RH	Without condensation
	Storage temperature	-10°C to +80°C	
	Cooling method	Free air circulation	
Protection	Short circuit	Yes	
	Overcurrent	Yes	Rectangular characteristic
	Automatic recovery on fault remove	Yes	
Safety and EMC	Withstand isolation voltage	3 kVAC (input to output)	5 mA, 1 min
	Isolation class	2	Grounding is not required
	Safety compliance	EN60950, EN60335	
	EMC compliance	EN55022, class B	
	Marking	RoHS, CE	
Mechanical	Dimension	174 × 72 × 42 mm	L × W × H
	Enclosure	Black ABS plastic	Desktop type
	Weight	584 g	
	Input connector	IEC320 C7 2-pole socket	
	Output connector	DC Jack 2.1 × 5.5 × 11 mm	Plus in the middle
	Output cable	1.5 m	0.82 mm <sup>2</sup>
	Single package	200 × 80 × 90 mm	
	Packing	425 × 420 × 200 mm	20 pieces
Country of manufacturing	China		

## Notes:

Unless otherwise stated, all parameters are specified at 230 VAC input voltage, 50 Hz, ambient temperature 25°C and relative humidity 70% for rated load output. The values of parameters related to the output voltage regulation is measured from low to high line or for load changes from 0 to 100%, respectively. The power supply (charger) is considered as an independent unit, but the final equipment still need to reconfirm that the whole system complies with the EMC directives. If the PSU is installed in the final device as a subassembly, the tests should be repeated to verify that the system has been met compliance. Detailed technical data are available on request.

## BLOCK DIAGRAM

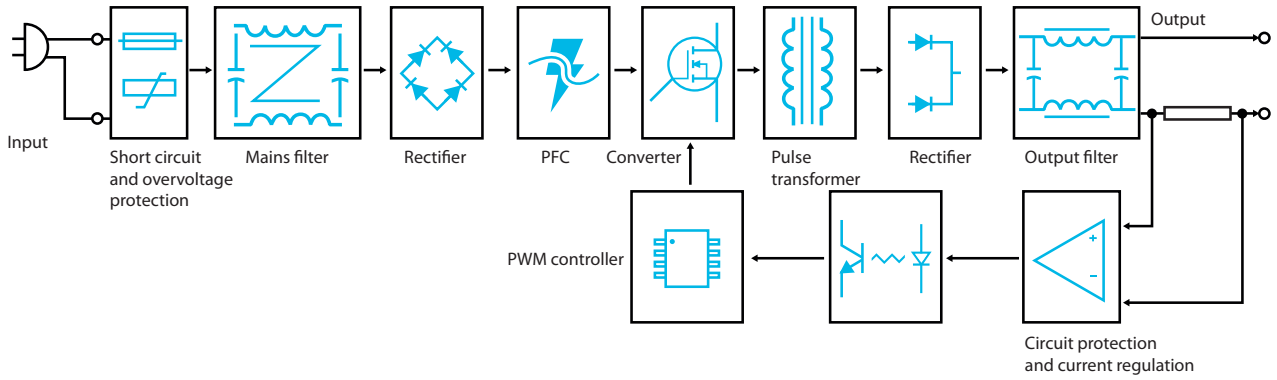

## MECHANICAL SPECIFICATION

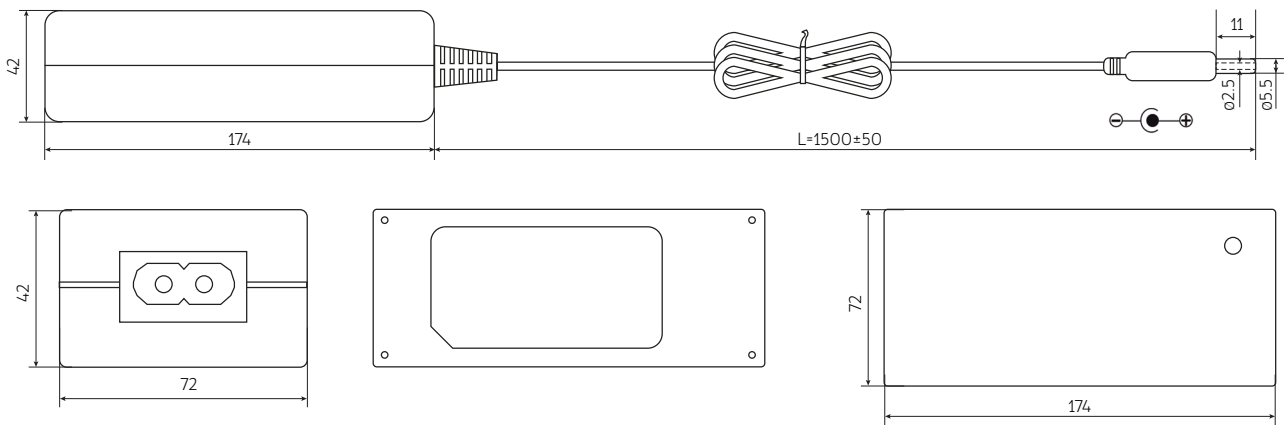

## PRODUCT LABEL



**Attention.** The charger is designed to work with a lithium-ion battery pack with a built-in balancer system. Its use for charging packages without a balancing system is only possible if the cell manufacturer allows such a possibility, e.g. for cells of the same type and from the same batch, and for charging with low current. If in doubt, please check the cell manufacturer's recommendations (datasheet) and follow the recommendations contained therein.

### Legend to the label icons:

- - II safety class: no grounding is required, no dangerous voltage even in an emergency situation will appear on output
- ⊕ ⊖ - polarization: plus in the middle, minus outside
- 🏠 - power supply intended for indoor use only
- ♻️ - the product must not be disposed of in normal waste containers

## LED STATUS INDICATORS

State	Conditions	LED red	LED green
No battery	No battery connected to charger	○	●
Charging	Output current over 4800 mA	●	○
Battery charged	Output current below 350 mA and battery voltage over 16.2 V	○	●

## MARKING SYSTEM

**CL16.8VDC-5.0A**

- Charging current **5,0 A**
- Rated voltage **16,8 V**
- Series **CL**